

150 tons Hydramarine AHC Crane – FULLY REFURBISHED, REACTIVATED & 12 MONTHS WARRANTY



Year of Build	2008
Class	DNV Design
Manufacturer	Hydramarine
Type	HMC 3568 LKO 250-32 (750-20) (1000-15) (1500-10)(100-33) AHC
SWL	150t @ 10 meters / 100t @ 15 meters / 25t @ 32 meters
Working Depth	2,000 meters
Wire Diameter	OD Ø64 mm
Drum Diameter	Ø 1787 mm
Min outreach	10 meters
Max outreach	32 meters
Man-riding	1.5t @ 34 meters outreach
Hoisting speed	Single line, 0-33 tons: Approx. 0-60 m/min
Aux Winch	10t @ 34-meter outreach – 400 meters travel length
Weight	235 tons approx.
Power Requirements	3x 690V / 3x 300 kW
Location	Singapore
Delivery time	3-4 months subject to availability of spares after agreement

This document and all data disclosed herein or herewith are the confidential and proprietary property of **HYDRAMARINE A.S.** and are not to be used, reproduced or disclosed in whole or in part by or to anyone without the written permission of **HYDRAMARINE A.S.**

Dimensions without tolerances tolerances to comply with: NS/ISO 2768/1 tolerance class "medium".		Welds to comply with: GRADE B NS 470.		
Rev.	Description	Drawn	Checked	Date
A	ISSUED FOR IDC	MJ	SVB	13.11.07
0	ISSUED FOR PRODUCTION	MJ	SVB	16.11.07

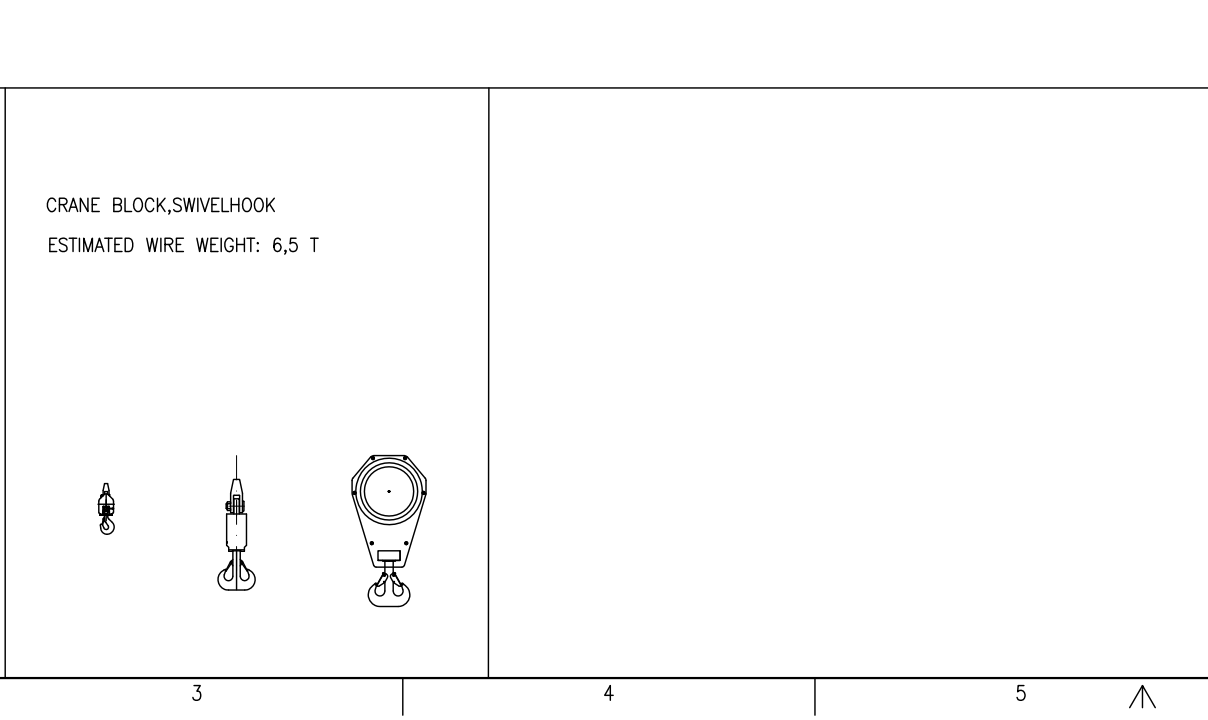
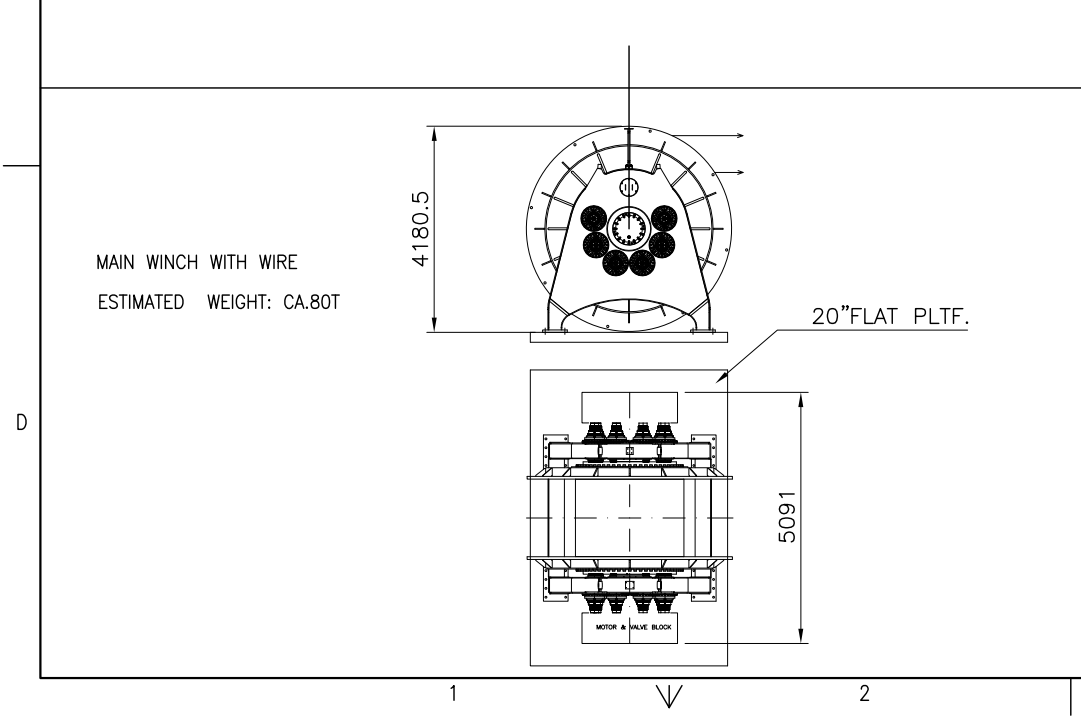
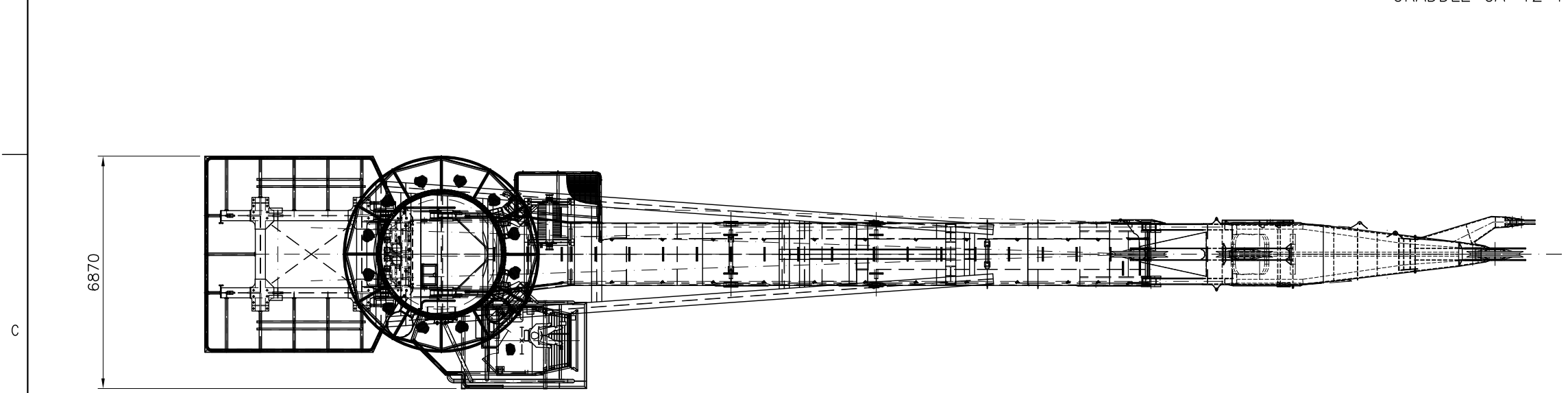
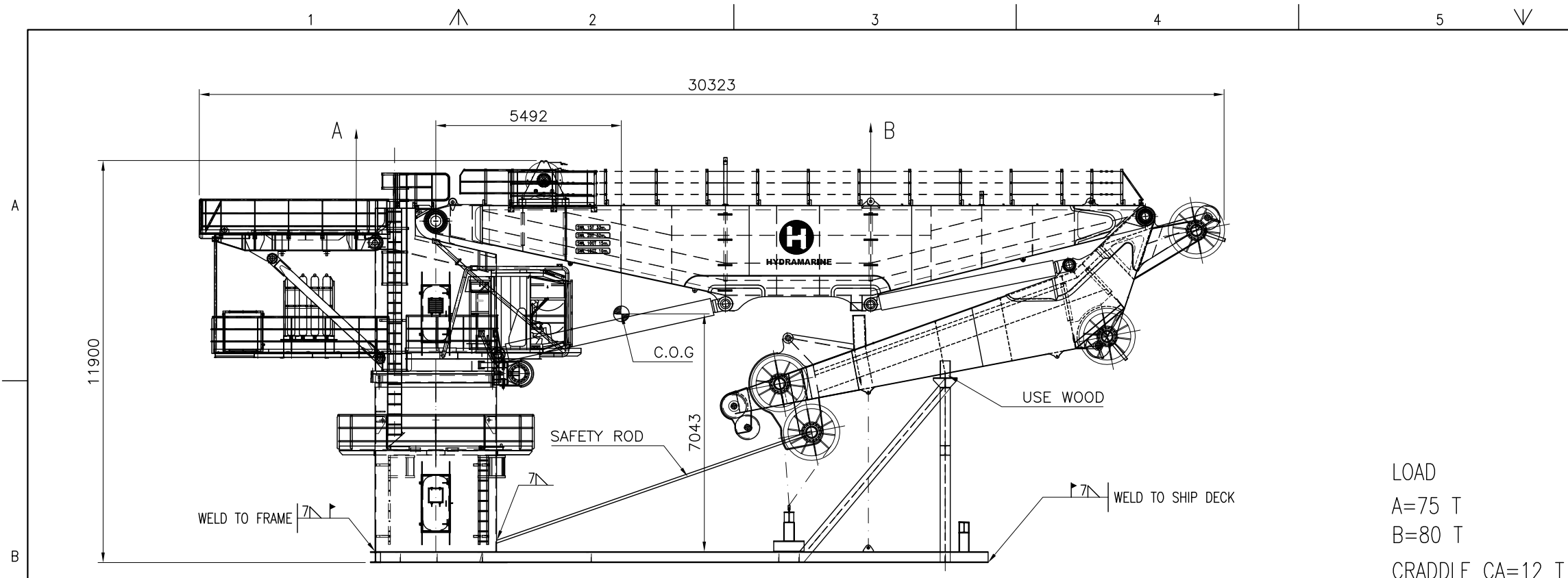

Drawn/Date: SOU 20.09.06	Projection ☐	Scale/format: 1:150	HYDRAMARINE Kristiansand NORWAY Tel.: +47 38 01 87 00 • Fax: +47 38 01 87 01
HMC 3568 LKO 250-32 (750-20)	Project/Customer SP 1921	AutoCAD file: C.3568.0028.TR03	REV. 1
THIS IS A COMPUTER AIDED DRAWING AND MUST NOT BE ALTERED MANUALLY.			