

YARD

BIBLIOGRAPHY

높이를 1200mm에서 3000mm로 1.8m
(2005. 04. Owner)

R2 : 1.

TRUNK 구조 추가. (2018. 02. Owner)

PRINCIPAL DIMENSIONS

LENGTH (O A)	111 .00 M
LENGTH (P P)	108 .00 M
BREADTH (MLD)	20 .00 M
DEPTH (MLD)	7 .20 M
DRAFT (MLD)	5 .20 M
DRAFT (SCANT)	5 .30 M
DEAD WEIGHT	(ABT) 7,500 T
CLASS	KR
NAVIGATION AREA	COASTING SERVICE



ISSUED FOR APPROVAL
2018.03.20

NOTES

- BOTH SIDES ARE SYMMETRICAL ABOUT CENTER LINE OF SHIP.(EXCEPT AS SHOWN.)
- ALL PLANS ARE LOOKING DOWNWARD, ALL SECTIONS ARE LOOKING FORWARD & ALL ELEVATIONS ARE LOOKING PORT.
- STIFFENER END CONNECTION
 - S OR → ; END SNIPED
 - B ; BRACKET CONNECTION
 - W OR NO MARK ; WELDING CONNECTION
- GRADE OF STEEL
 - NO MARKED STEEL ; GRADE 'A' MILD STEEL (MIN. YIELD STRESS = 235 N/mm²)
 - "KB,KD" MARKED STEEL ; GRADE 'B,D' MILD STEEL (MIN. YIELD STRSS = 235 N/mm²)
- THICKNESS & GRADE OF COLLAR PLATE TO BE SAME OR MORE THAN WEB PLATE.
- MIN. LEG LENGTH OF DOUBLE CONTINUOUS FILLET WELDING TO BE 5.0 mm EXCEPT AS SHOWN.

SHIP YARD :	YARD NO. :		
SHIP NAME :	OWNER :		
PROJECT :			
APP. BY :	MIDSHIP SECTION		
CHK. BY :			
DWN. BY :			
SCALE : 1 / 50	DATE : 2018. 02.	DWG. NO. : H-001	REV. NO. : R2

ORDINARY SEC. 3/5 2/8

FRAME SPACE : 600mm

ORIGINAL

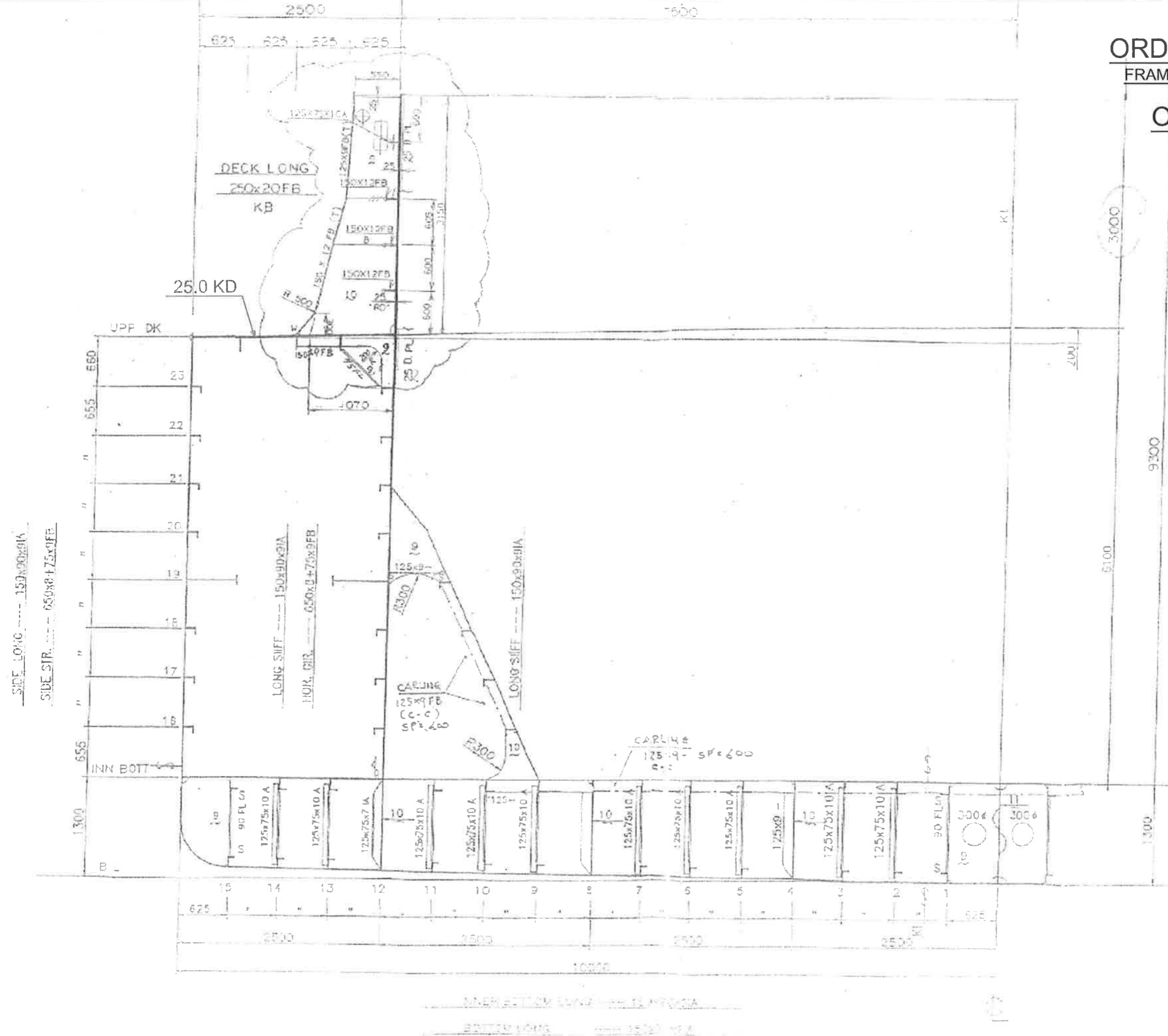

MARSHALLS LANE - 11/1/2004
BOTTOM LONG - 11/1/2004

ORDINARY SEC.
FRAME SPACE : 600mm

REVISED

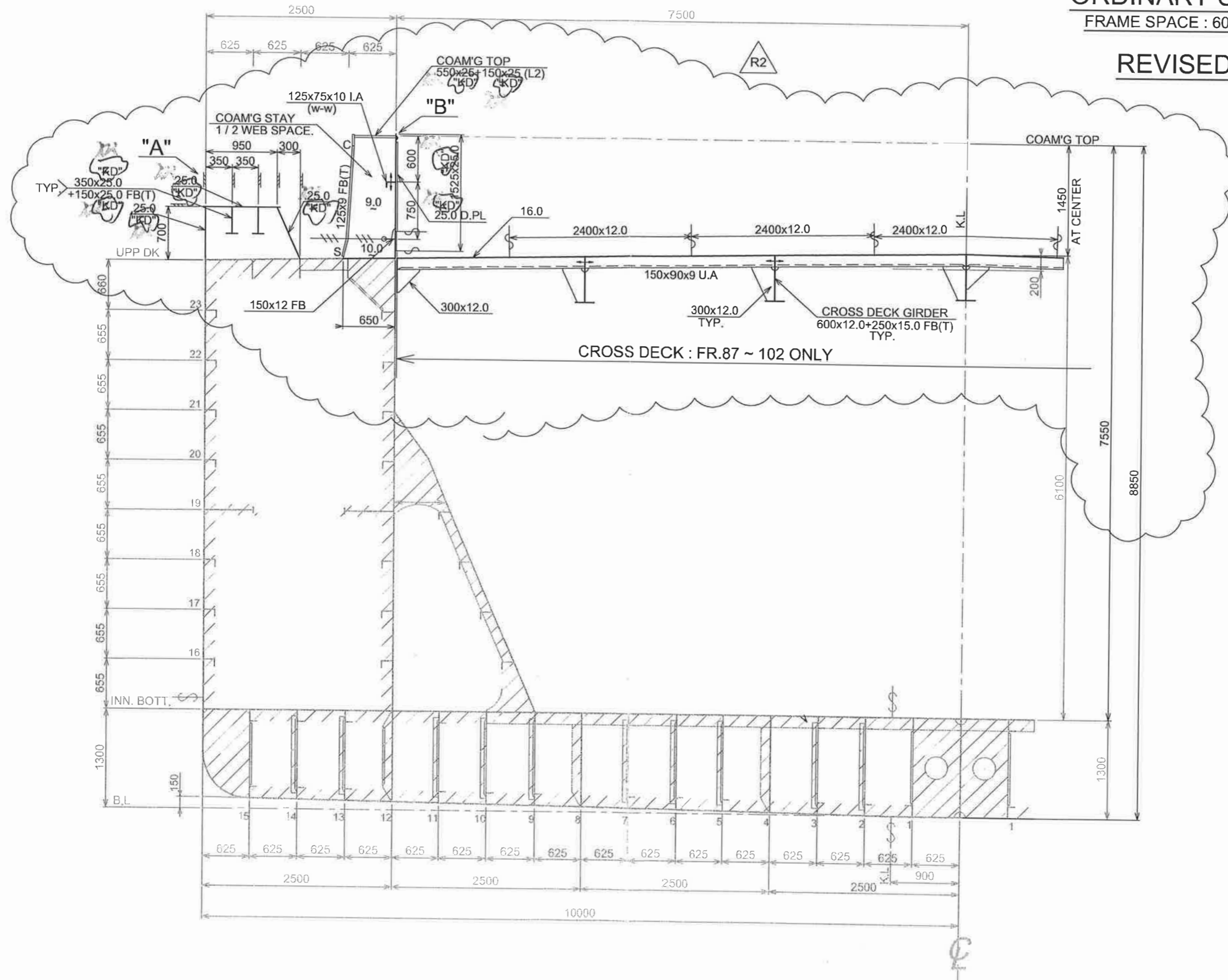

TYP. WEB SEC.
WEB SPACE : 1800mm

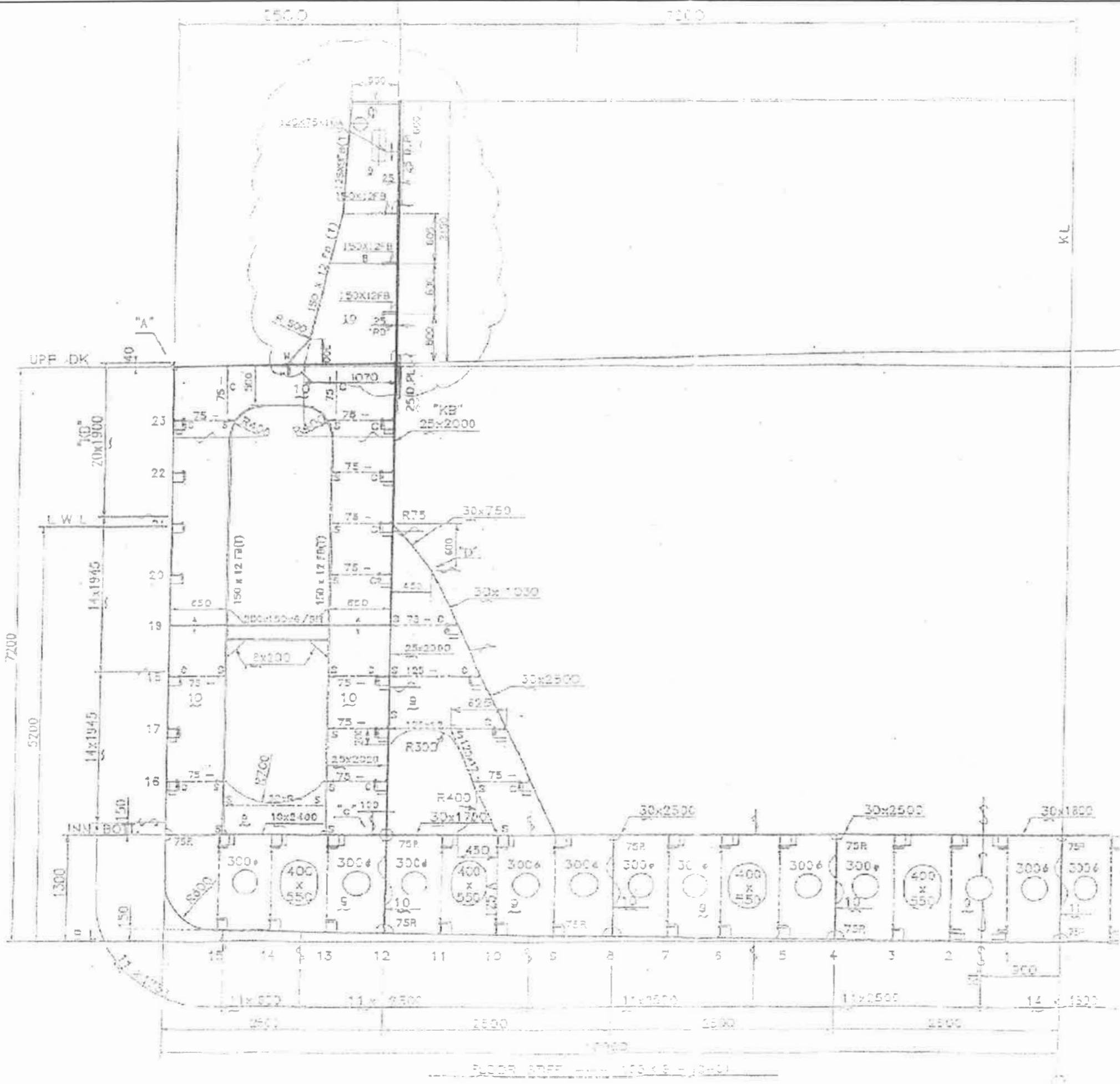

FR.87 SEC.

FR.102 SEC. SYM. TO THIS (EXC. AS SHOWN)
REFER TO TYP. WEB SEC. (EXC. AS SHOWN)

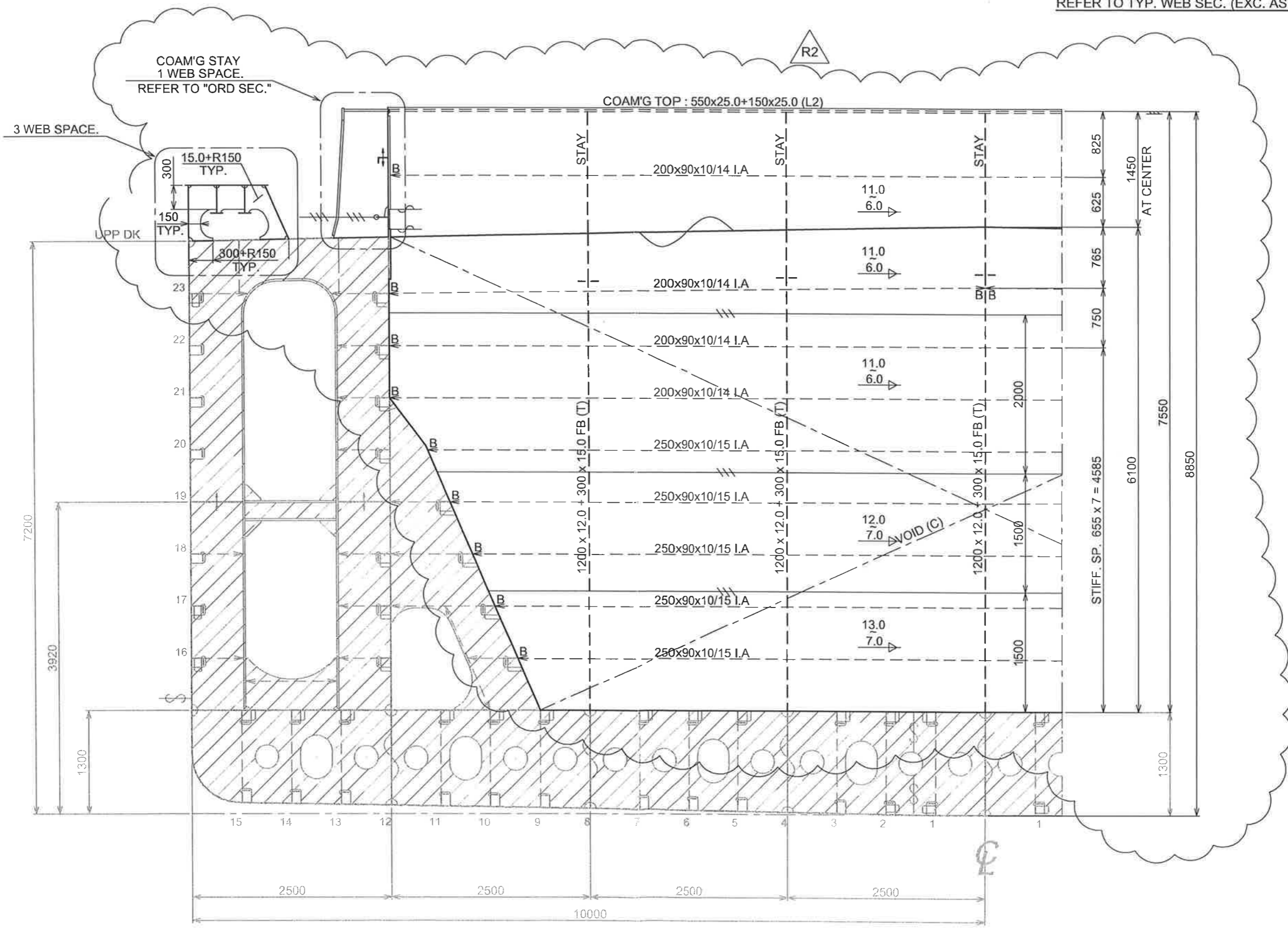

FR.93 SEC.

FR.90,96,99 SEC. SIM. TO THIS (EXC. AS SHOWN)
REFER TO TYP. WEB SEC. (EXC. AS SHOWN)

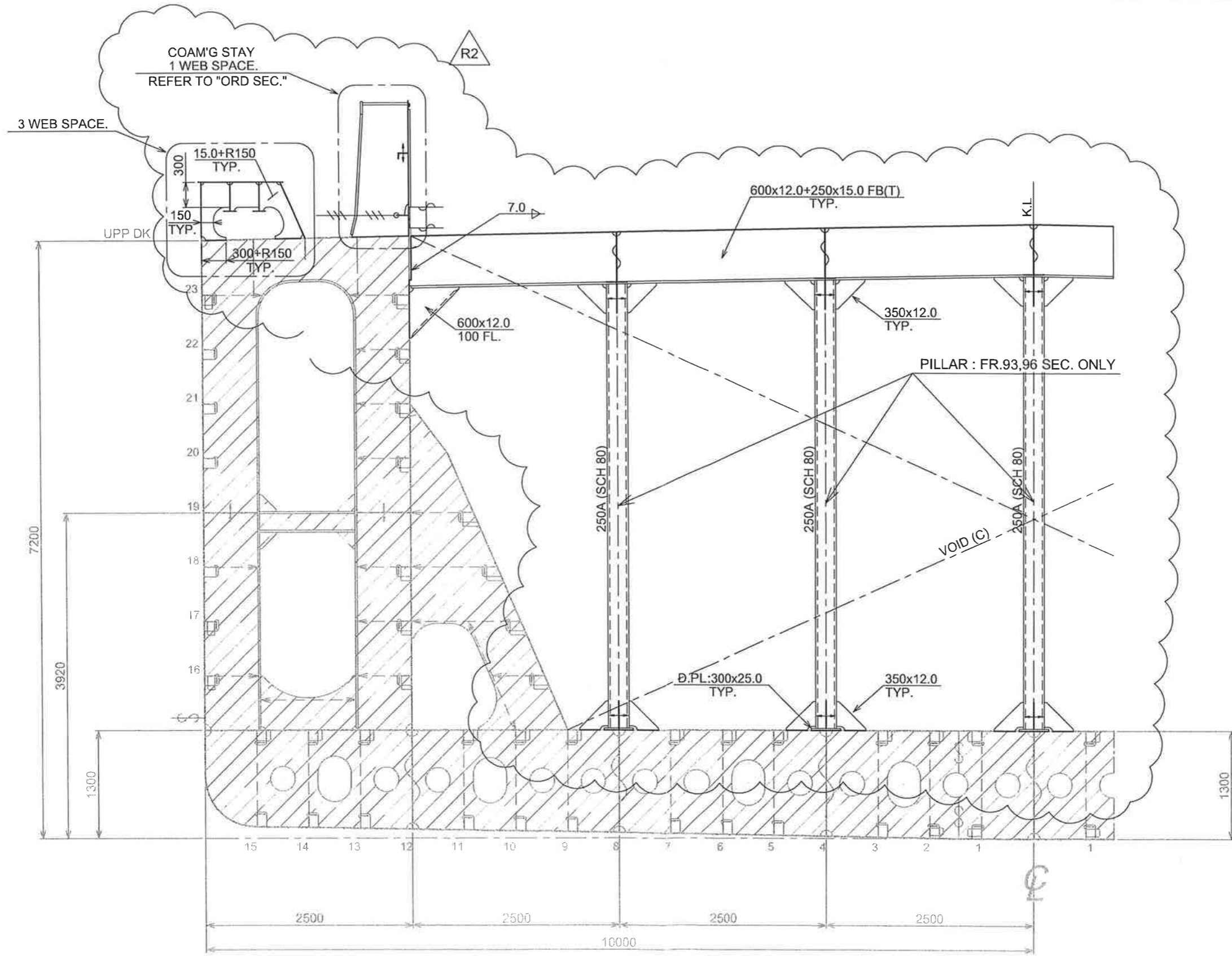

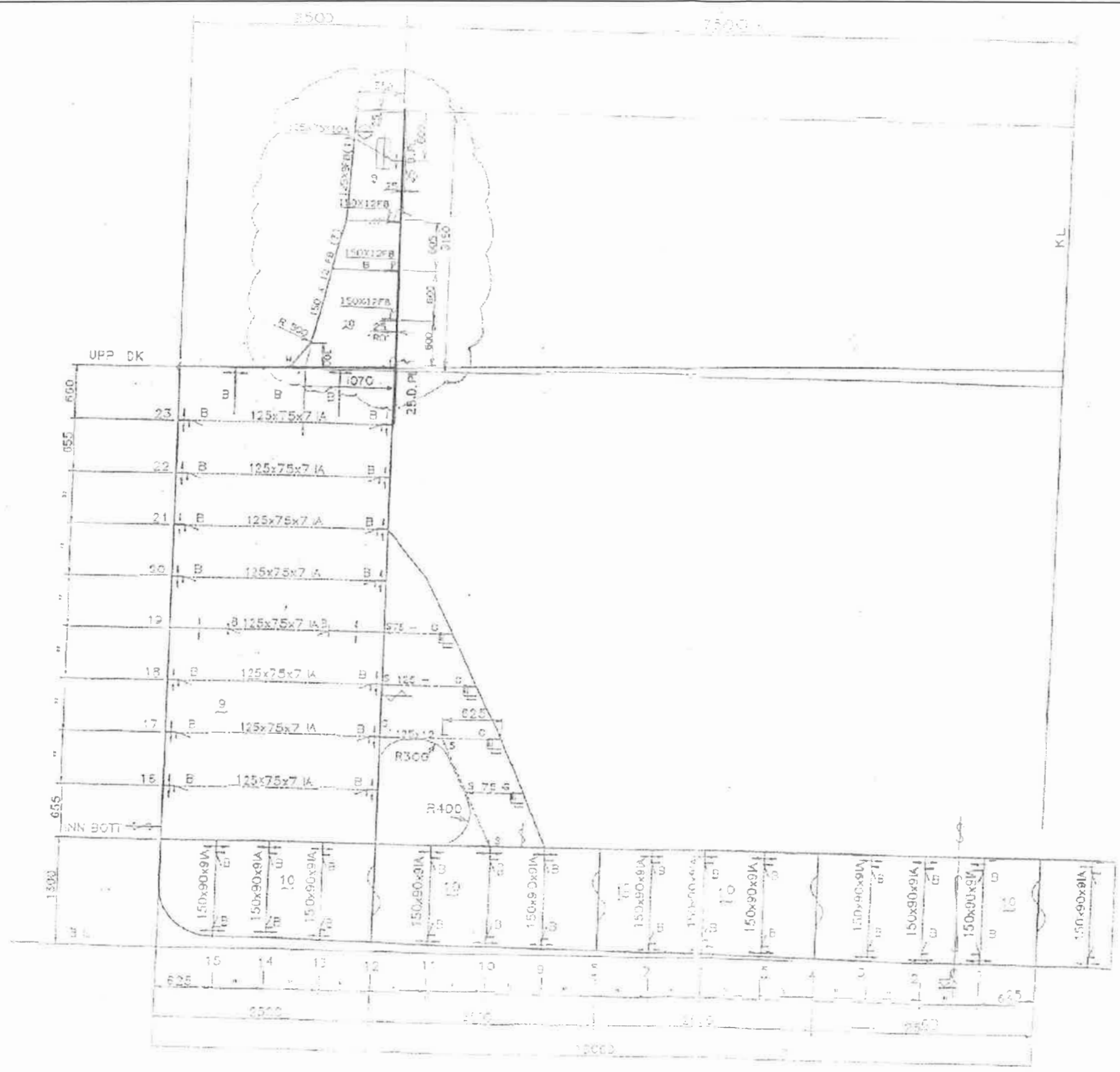

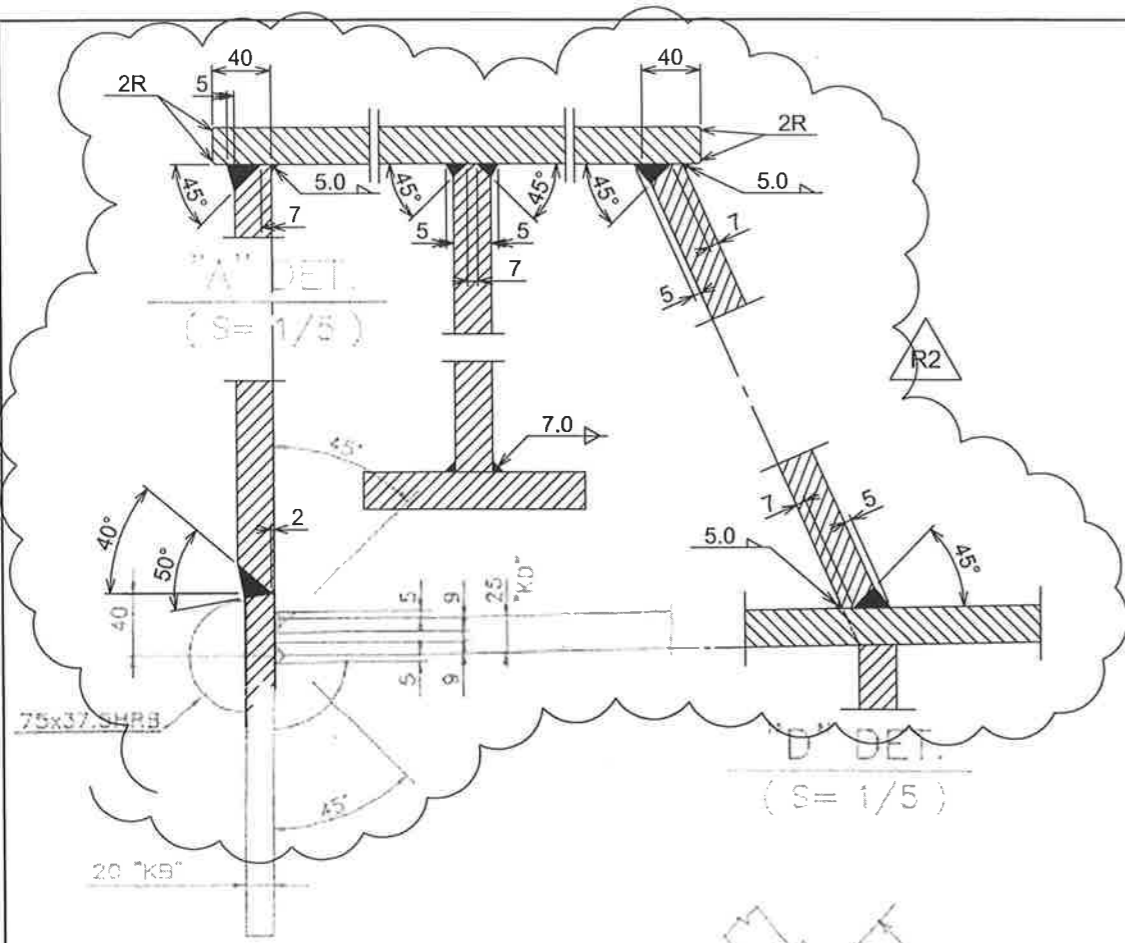

75x37 SHRB
20 "K9"

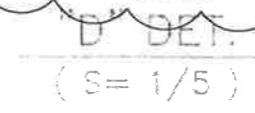

"B" DET.
(S=1/5)

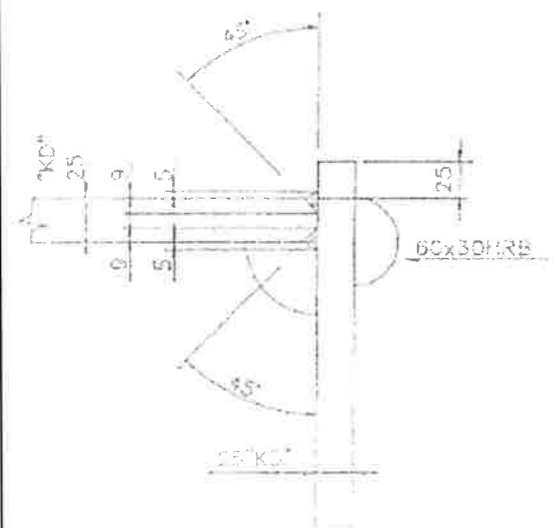

"C" DET.
(S=1/5)

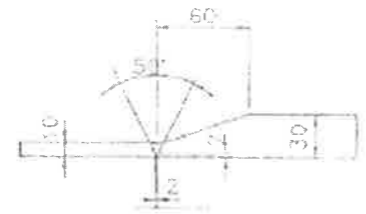

CENT. GIR. SEC.

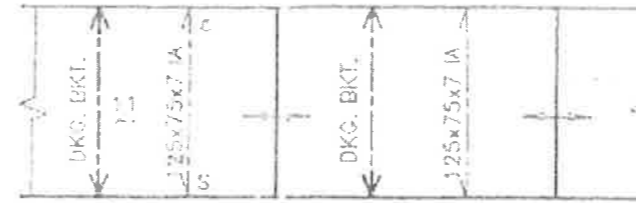

SIDE GIR. SEC.

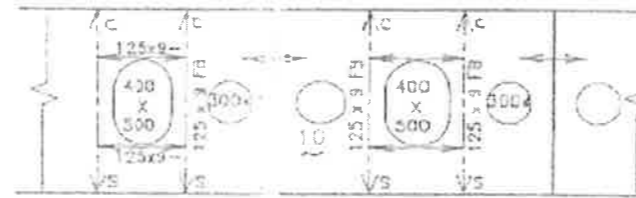

BOTT. LONG FR.

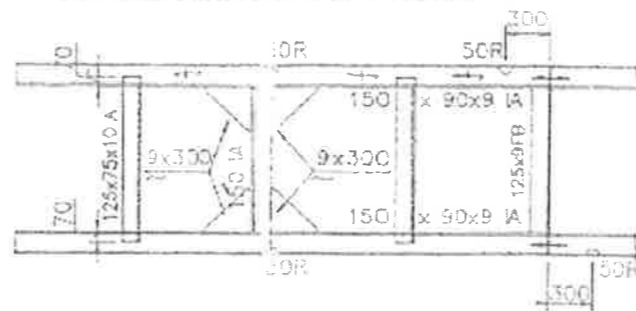

UPPER DECK LONG BM

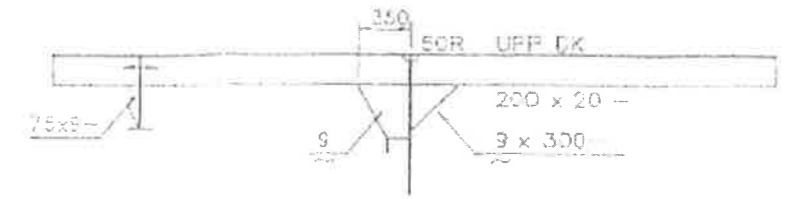

SIDE STR.

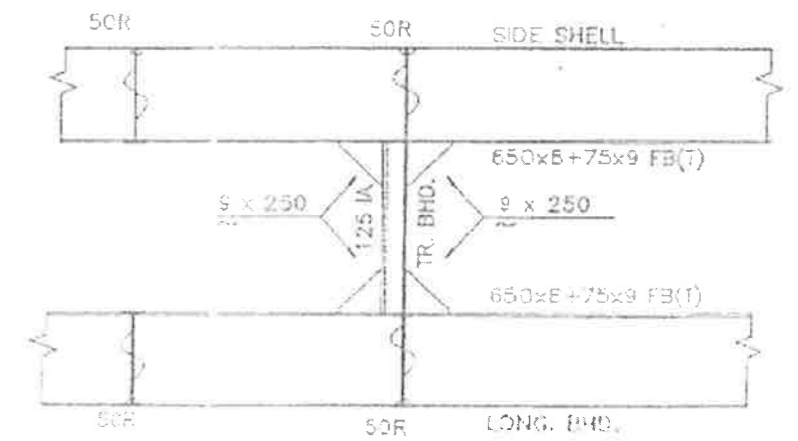

SIDE LONG. FR.

